



C - PS



C - GGC



C - FSV



C - TMBV



C - FBV



C - CBV



C - MMBV



C - FWBV

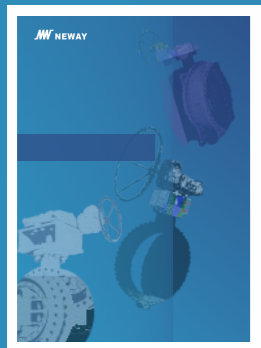

C - BFV

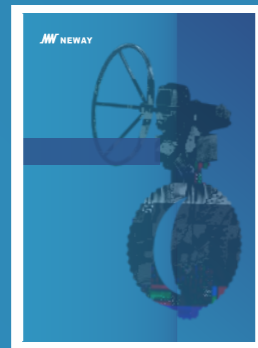

C - DOV



C - TOV



C - CPS



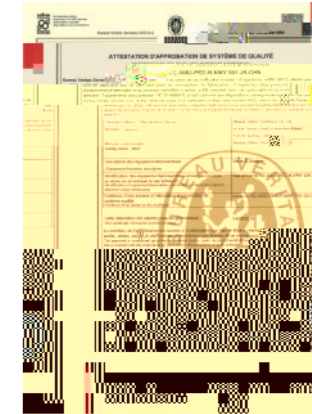
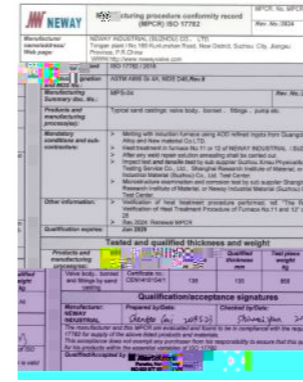
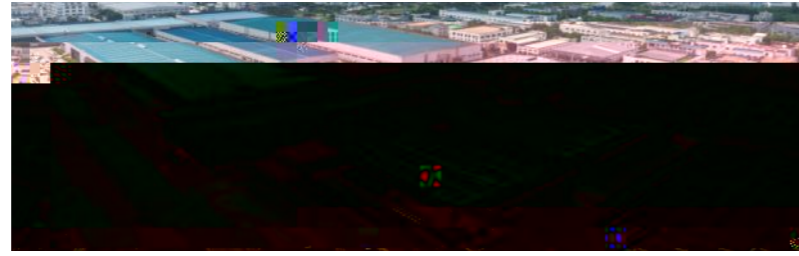

NORSOK

ISO9001

CE/PED



ABS



AD2000

1 1 3 1 1 230,000  
 Ansys Fe-safe CF-design SiemensPLM NX  
 SAP

ISO API

CE-PED ISO 9001 , API 6A, API 6D, API 600

AD2000 TA-Luft,

API 624, ISO 15848 API 607, API 6FA

80

- 1
- 2-3
- 4
- BBG/BG
- 5
- 6-7
- BDG
- 8
- 9
- BSG
- 10-11
- 12-14
- BEG
- 15
- 16-17
- 18-19
- 20



①

1	Class 150, 300	3/8" -8"	1	Class 150, 300	1" -40"
2	Class 600	3/8" -3"	2	Class 600, 900	1" -40"
3	Class 900, 1500	3/8" -2"	3	Class 1500	1" -24"

②

BBG		Class 600	2"	BSG		
BG				BEG		
BDG						

③

	1	3	6	9	15
Class (LB)	150	300	600	900	1500

④

R		S	
J	RTJ	N	NPT
B			

⑤

G		M	
		P	

⑥

	S00	S01	S02	S03	S40
	CF8	CF8M	CF3	CF3M	F304
	A351 Gr.CF8	A351 Gr.CF8M	A351 Gr.CF3	A351 Gr.CF3M	A182 Gr.F304

	S41	S42	S43
	F316	F304L	F316L
	A182 Gr.F316	A182 Gr.F304L	A182 Gr.F316L

⑦

1	RPTFE	G		22	F304	22	F304	22	F304
3	PEEK	L	Lipseal	26	F316/F316L	26	F316/F316L	26	F316/F316L
8	PCTFE			30	F304/F304L	30	F304/F304L	30	F304/F304L
A	Vespel SP-211			2X	FXM-19	2X	FXM-19	2X	FXM-19

ERP

CNC

CNC



(MPI)、冲

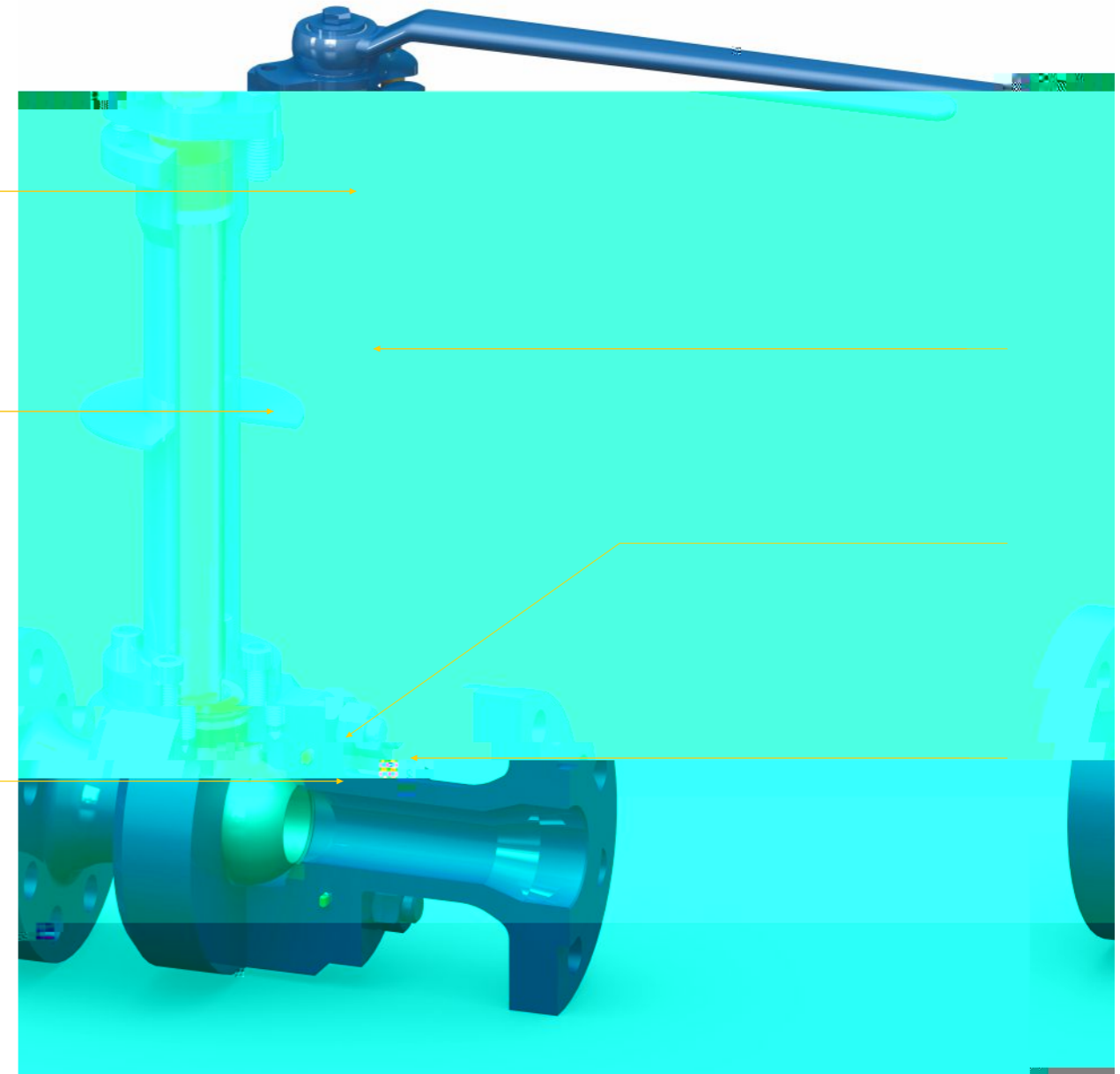
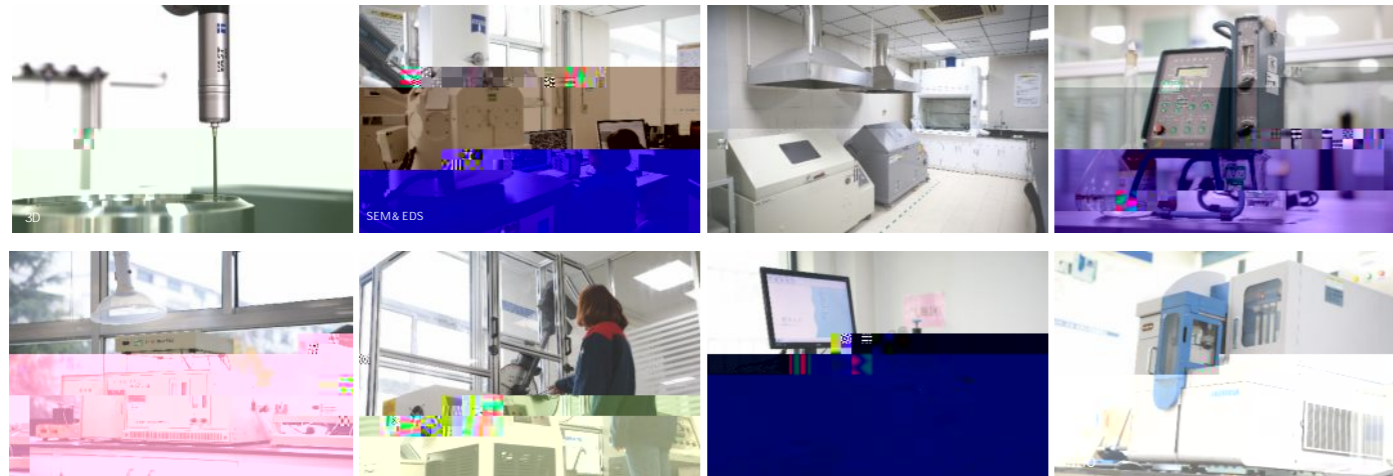

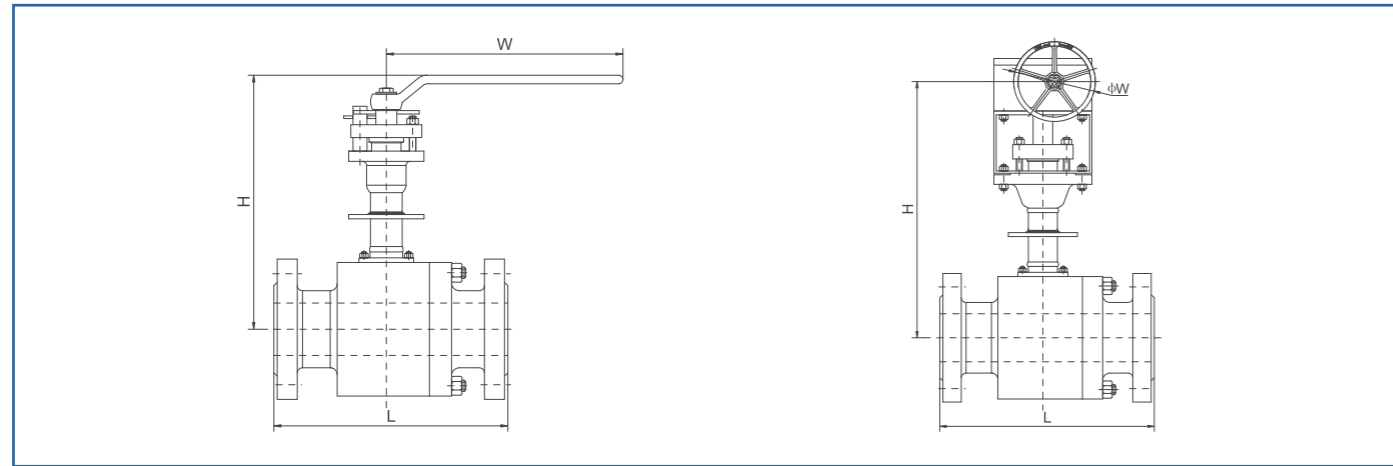

Class 150

NPS	in	1/2	3/4	1	1-1/2	2	3	4	6	8
DN	mm	15	20	25	40	50	80	100	150	200
(RF)L	mm	108	117	127	165	178	203	229	394	457
H	mm	326	336	343	416	432	508	602	739	783
W	mm	165	215	215	350	430	815(T)	815(T)	500(G)	500(G)
WT(RF)	KG	4	5	7	16	22	43	62	180	289

Class 300

NPS	in	1/2	3/4	1	1-1/2	2	3	4	6	8
DN	mm	15	20	25	40	50	80	100	150	200
(RF)L	mm	140	152	165	191	216	283	305	403	502
H	mm	328	340	347	420	439	516	615	789	843
W	mm	165	215	215	350	430	815(T)	815(T)	500(G)	500(G)
WT(RF)	KG	5	6	8	18	24	51	79	212	386

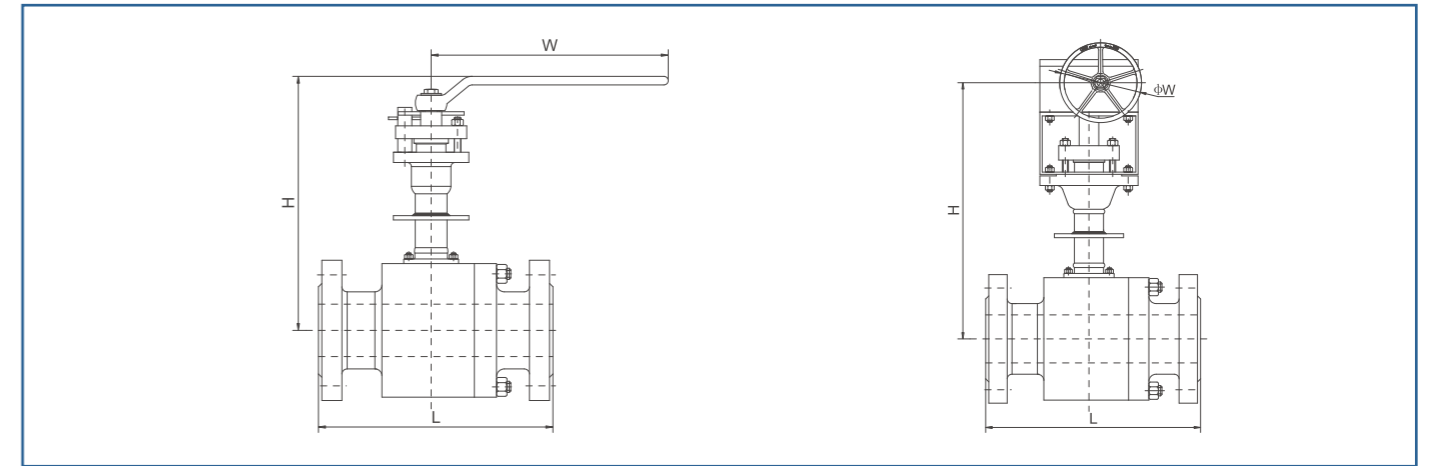

Class 600

NPS	in	1/2	3/4	1	1-1/2	2	3
DN	mm	15	20	25	40	50	80
(RF)L	mm	165	191	216	241	292	356
H	mm	337	347	361	423	510	652
W	mm	215	215	350	600	300(G)	400(G)
WT(RF)	KG	8	9	15	27	52	82

Class 900 / 1500

NPS	in	1/2	3/4	1	1-1/2	2
DN	mm	15	20	25	40	50
(RF)L	mm	216	229	254	305	368
H	mm	354	369	400	482	579
W	mm	215	150(G)	203(G)	300(G)	400(G)
WT(RTJ)	KG	15	22	33	63	96

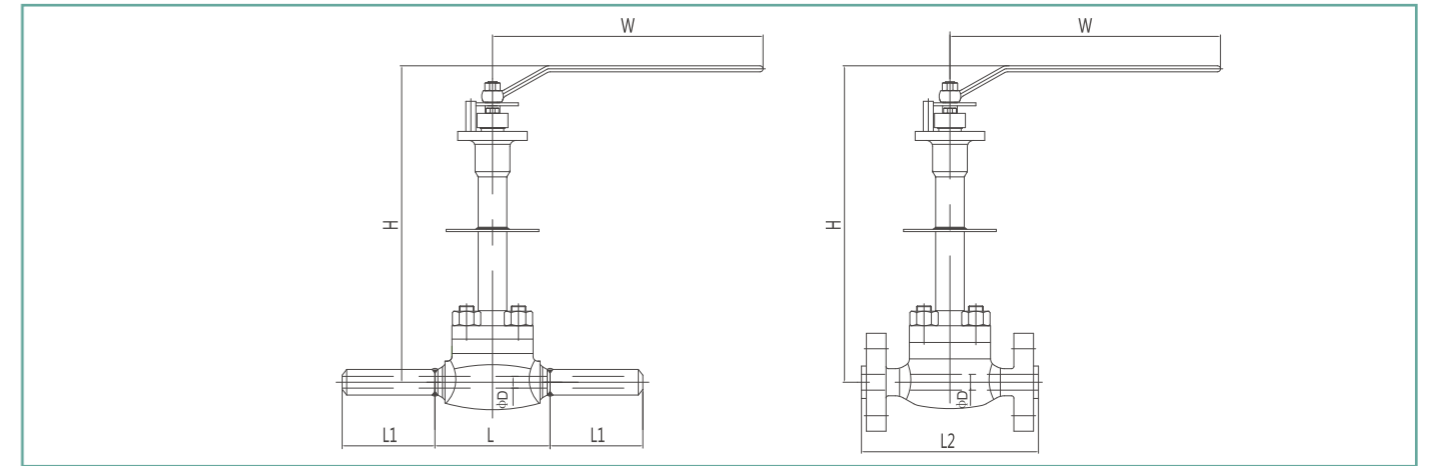
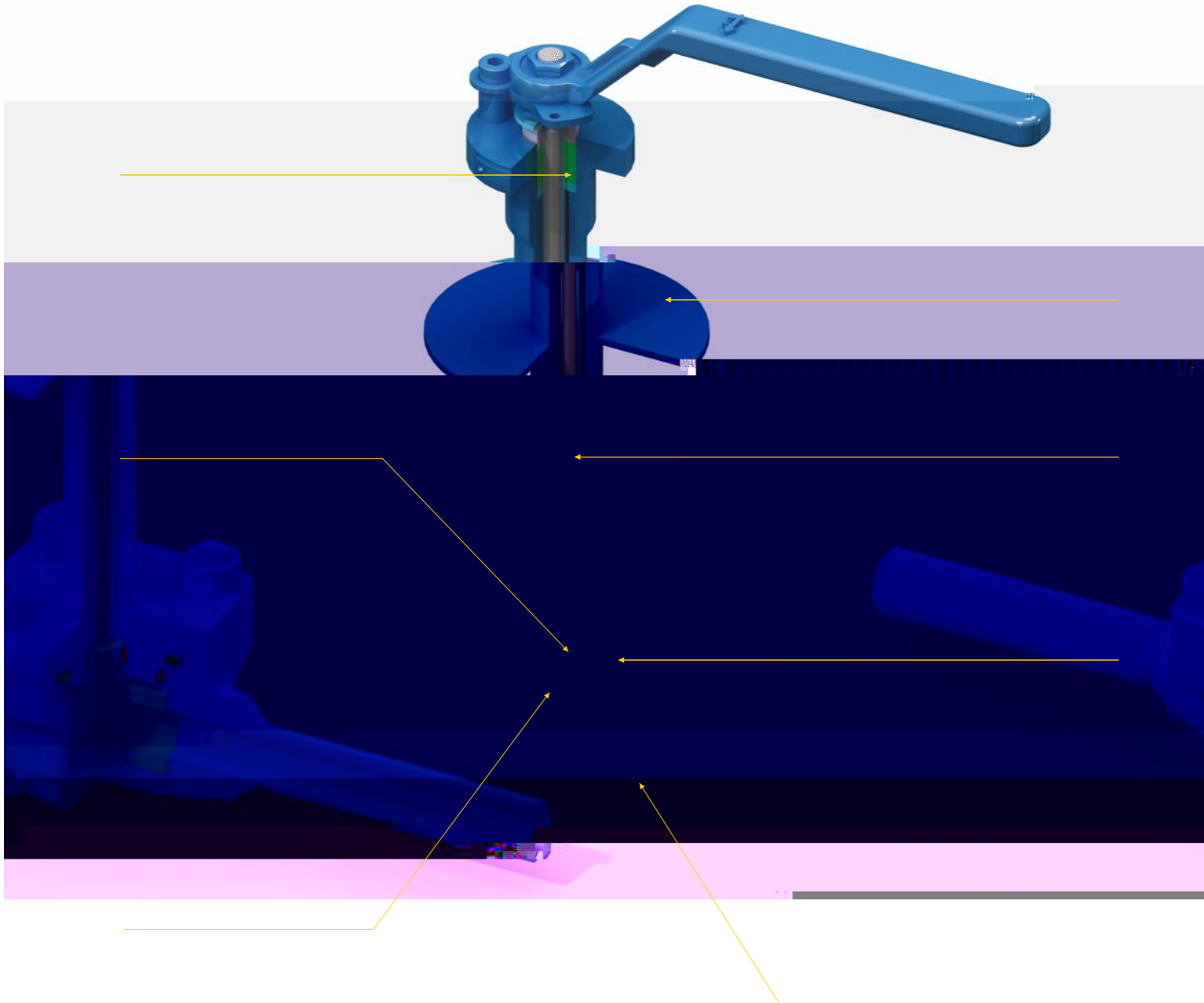

Class 150 / 300 / 600

NPS	in	1/2	3/4	1	1-1/2	2	3
DN	mm	15	20	25	40	50	80
L	mm	140	140	152	200	216	283
L1	mm	100	100	100	100	100	100
L2(RF)	mm	165	191	216	241	292	356
H	mm	330	330	350	430	440	550
W	mm	215	215	350	350	430	430*
WT (RF)	KG	8.5	8.5	12	28	43	96
WT (BW)	KG	8	8	11	25	40	87

Class 900 / 1500

NPS	in	1/2	3/4	1	1-1/2	2
DN	mm	15	20	25	40	50
L	mm	120	145	195	230	368
L1	mm	100	100	100	100	100
L2(RTJ)	mm	216	229	254	305	368
H	mm	435	435	480	510	550
W	mm	350	350	430	500	600
WT (RTJ)	KG	17	17	28	46	100
WT (BW)	KG	15	15	24	41	90

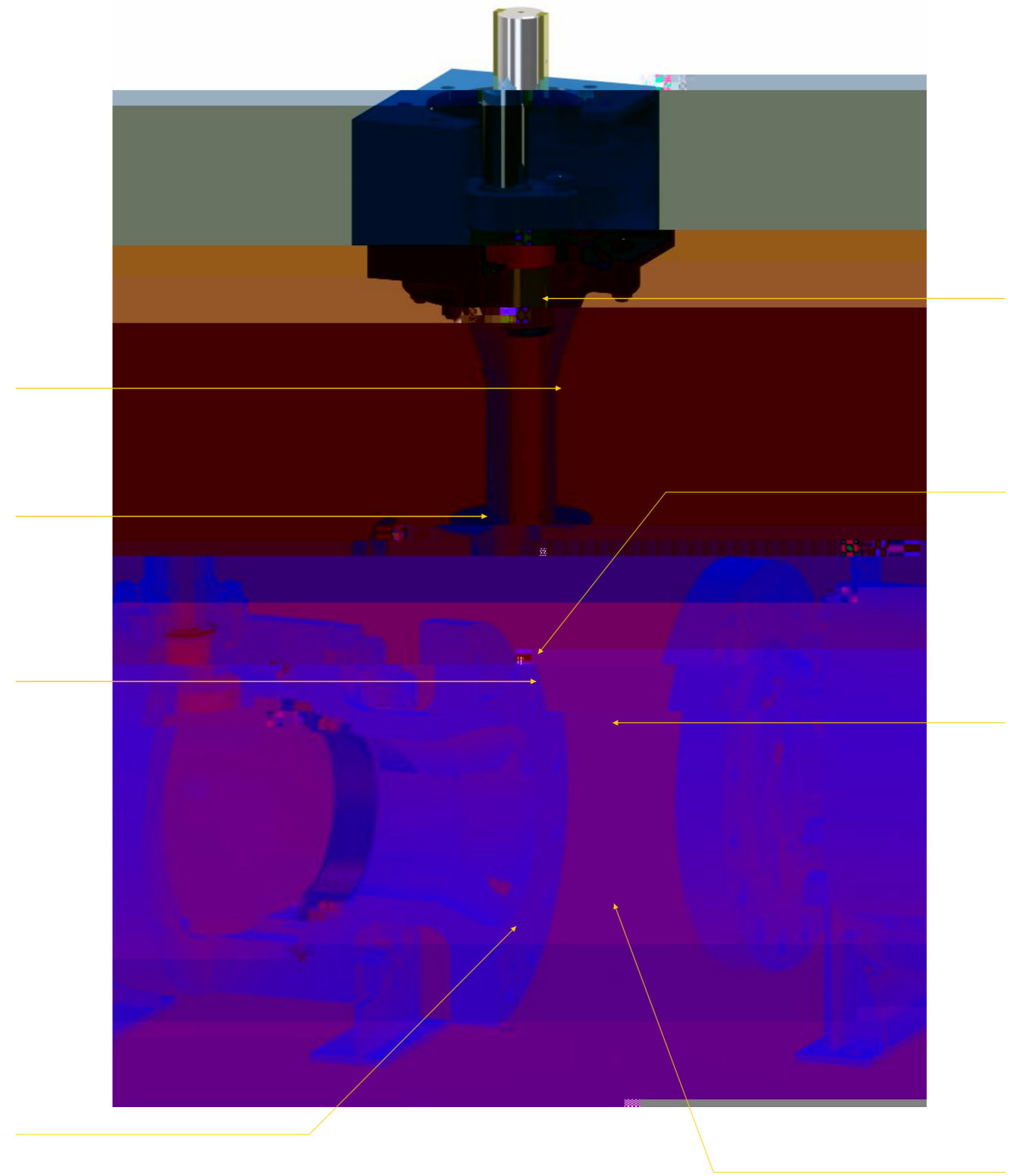

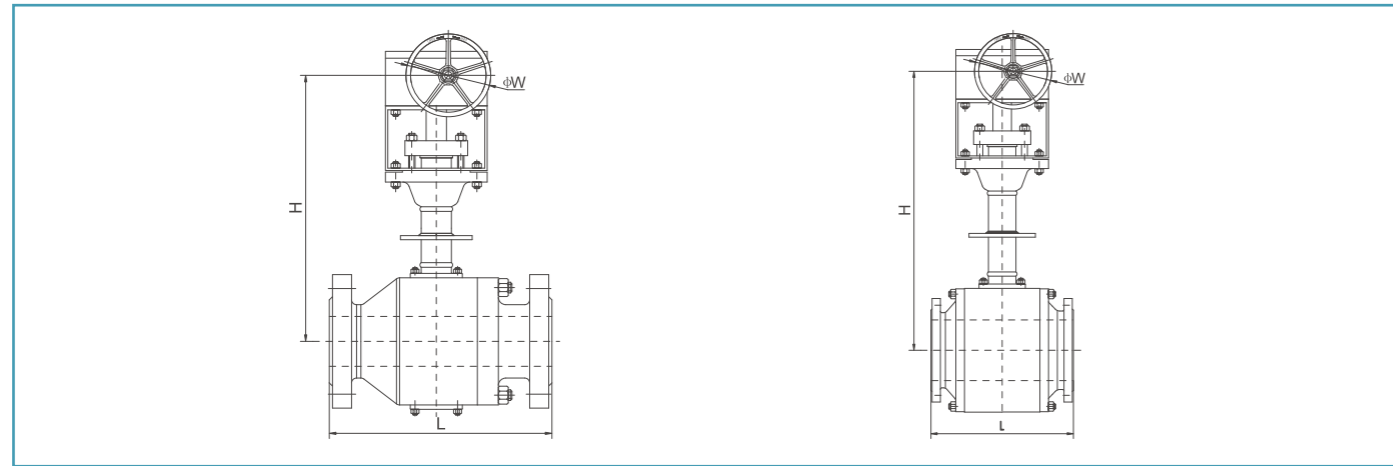

Class 150

NPS	in	2	3	4	6	8	10	12	14	16	18	20	22	24
DN	mm	50	80	100	150	200	250	300	350	400	450	500	550	600
L(RF)	mm	178	203	229	394	457	533	610	686	762	864	914	991	1067
L(BW)	mm	216	283	305	457	521	559	635	762	838	914	991	1067	1143
H	mm	472	591	669	847	948	1034	1068	1154	1186	1810	2020	2170	2470
W	mm	300	300	500	600	600	600	600	700	760	800	900	900	900
WT(RF)	KG	45	105	130	260	398	570	923	1380	1935	2295	3570	5040	6240
WT(BW)	KG	42	100	122	248	378	540	879	1320	1857	2200	3446	4880	6051

Class 300

NPS	in	2	3	4	6	8	10	12	14	16	18	20	22	24
DN	mm	50	80	100	150	200	250	300	350	400	450	500	550	600
L(RF)	mm	216	283	305	403	502	568	648	762	838	914	991	1092	1143
L(BW)	mm	216	283	305	403	502	568	648	762	838	914	991	1092	1143
H	mm	472	591	669	847	948	1034	1068	1154	1186	1810	2020	2170	2470
W	mm	300	300	500	600	600	600	600	700	760	800	900	900	900
WT(RF)	KG	50	111	144	286	613	719	1096	1385	1940	2300	3575	5045	6245
WT(BW)	KG	49	109	141	280	604	706	1077	1359	1906	2258	3525	4985	6174

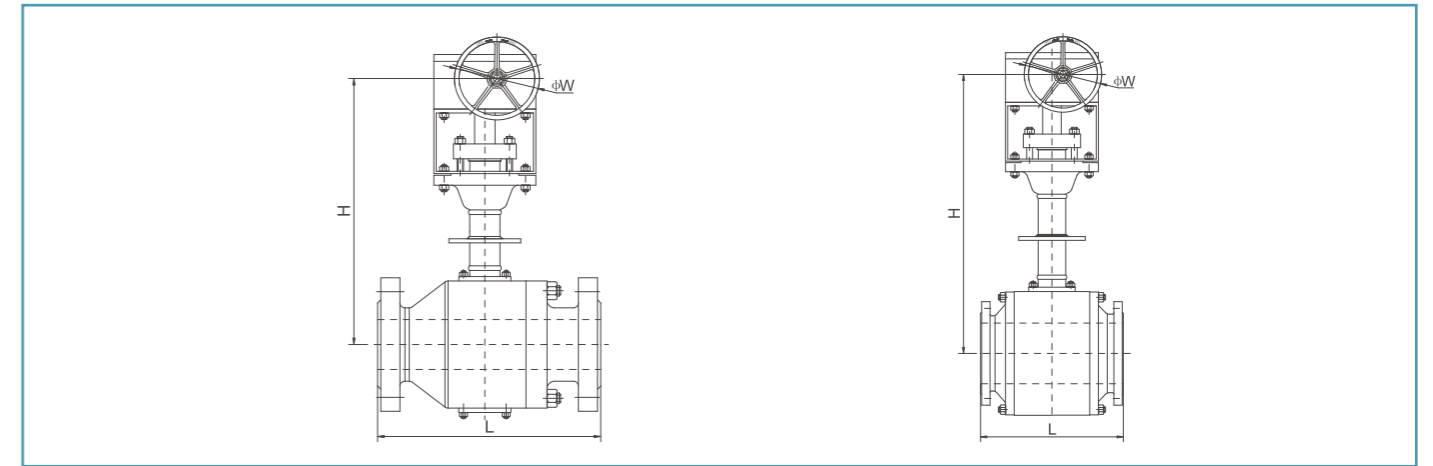

Class 600

NPS	in	2	3	4	6	8	10	12	14	16	18	20	22	24
DN	mm	50	80	100	150	200	250	300	350	400	450	500	550	600
L(RF)	mm	292	356	432	559	660	787	838	889	991	1092	1194	1295	1397
L(BW)	mm	292	356	432	559	660	787	838	889	991	1092	1194	1295	1397
H	mm	472	591	669	853	977	1046	1108	1184	1226	1840	2050	2200	2500
W	mm	300	500	500	600	600	760	760	760	760	800	900	900	900
WT(RF)	KG	60	116	196	359	719	987	1370	1674	1950	2310	3585	5055	6255
WT(BW)	KG	55	106	175	319	669	900	1260	1343	1760	2080	3305	4745	5883

Class 900

NPS	in	1/2	3/4	1	1-1/2	2	3	4	6	8	10	12	14	16	18	20	22	24
DN	mm	15	20	25	40	50	80	100	150	200	250	300	350	400	450	500	550	600
L(RTJ)	mm	216	229	254	305	368	381	457	610	737	838	965	1029	1130	1219	1321	1435*	1549
L(BW)	mm	216	229	254	305	368	381	457	610	737	838	965	1029	1130	1219	1321	1435*	1549
H	mm	460	460	460	500	500	630	687	890	1084	1144	1300	1550	1800	2060	2400	2650	2940
W	mm	200	200	200	300	500	500	600	600	760	760	800	800	800	900	900	900	900
WT(RTJ)	KG	18	25	35	63	165	277	618	745	1045	1562	1760	2266	2965	3380	5470	6750	7940
WT(BW)	KG	16	21	31	58	154	262	595	715	960	1425	1580	1960	2720	3070	5080	6180	7265

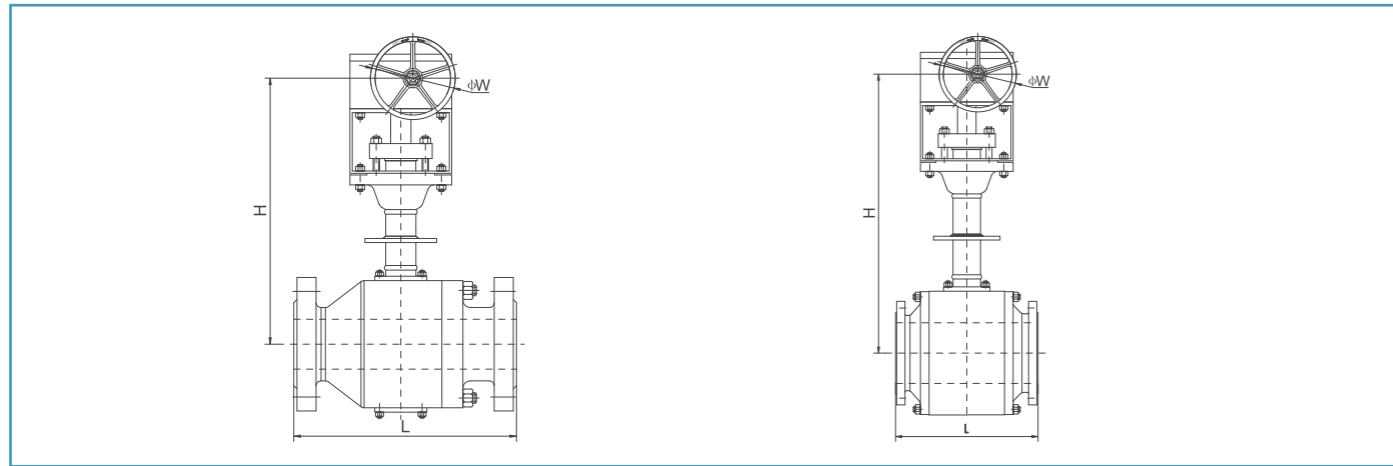

Class 1500

NPS	in	1/2	3/4	1	1-1/2	2	3	4	6	8	10	12	14	16	18	20	22	24
DN	mm	15	20	25	40	50	80	100	150	200	250	300	350	400	450	500	550	600
L(RTJ)	mm	216	229	254	305	368	470	546	705	832	991	1130	1257	1384	1537	1664	1803	1943
L(BW)	mm	216	229	254	305	371	473	549	711	841	1000	1146	1276	1407	1537	1664	1803	1943
H	mm	500	500	500	520	650	700	730	860	1020	1500	1590	1680	1890	1925	2175	2425	2680
W	mm	300	300	300	500	600	500	600	600	760	760	900	900	900	1000	1000	1000	1000
WT (RTJ)	KG	18	25	35	63	70	140	220	790	1120	1620	2950	3185	3850	5135	6180	7986	9675
WT (BW)	KG	16	22	31	57	50	105	178	660	912	1264	2415	2470	2921	3880	4662	6010	7181

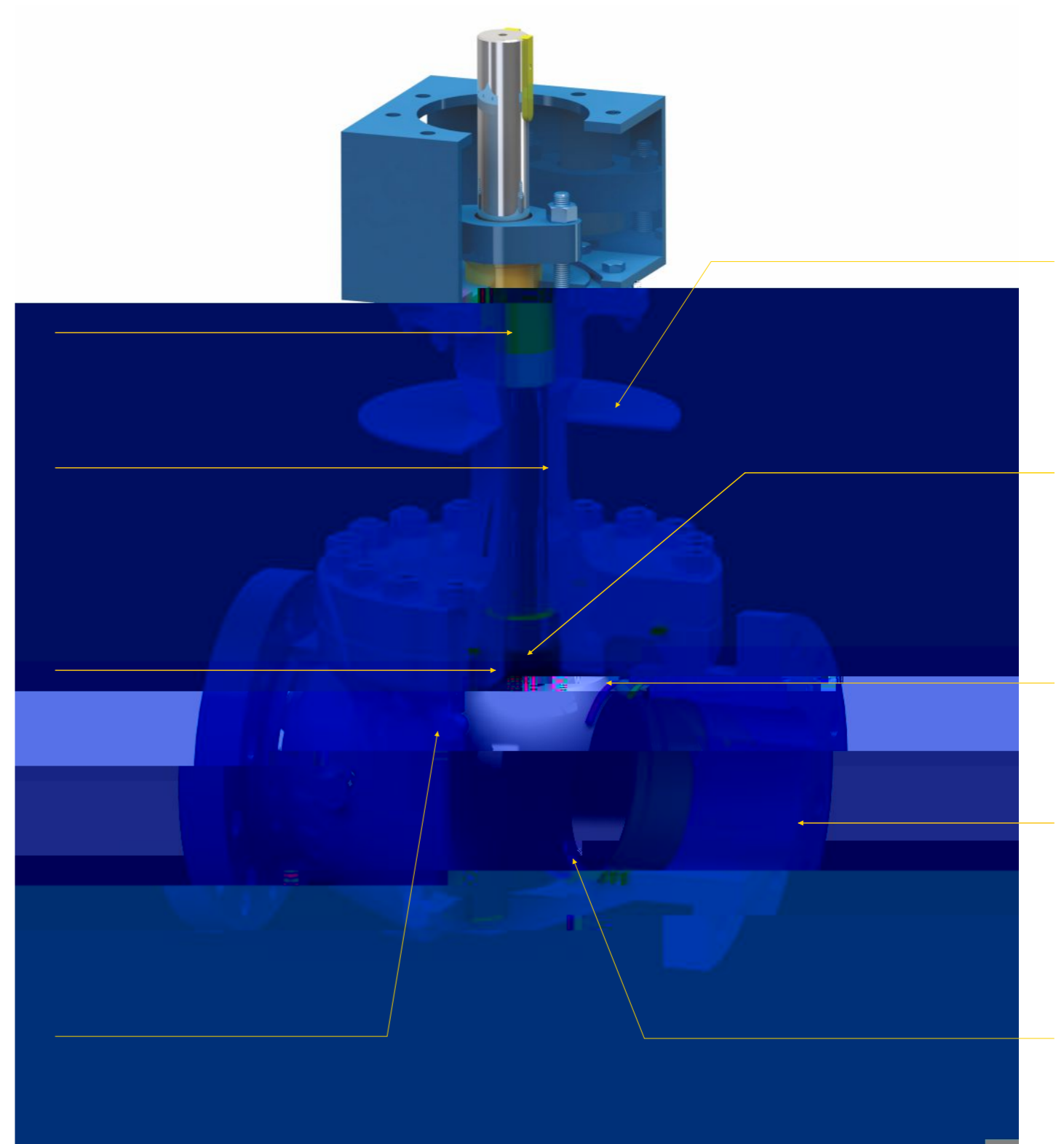

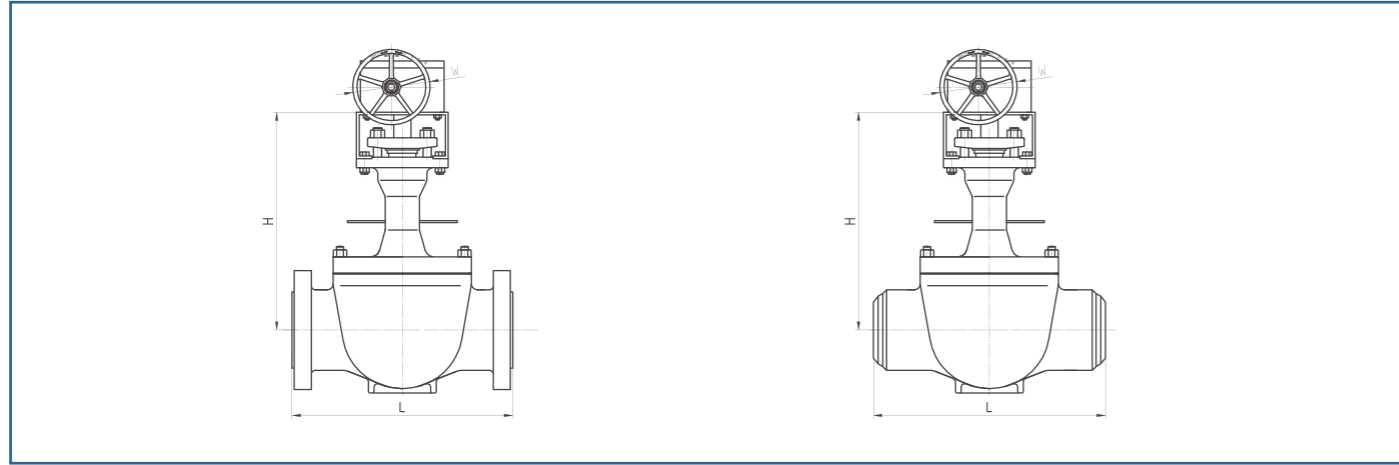

Class 150

NPS	in	1/2	3/4	1	1-1/2	2	3	4	6	8	10	12	14	16	18	20	22	24
DN	mm	15	20	25	40	50	80	100	150	200	250	300	350	400	450	500	550	600
L(RF)	mm	175	175	191	241	292	356	432	559	660	787	838	889	991	1092	1194	1295	1397
L(BW)	mm	191	191	191	241	292	356	432	559	660	787	838	889	991	1092	1194	1295	1397
H	mm	420	420	420	450	454	580	650	797	1004	1050	1100	1190	1230	1870	2100	2240	2550
W	mm	350*	350*	350*	300	300	300	500	600	600	600	600	700	760	800	900	900	900
WT(RF)	KG	31	32	36	45	49	95	160	292	584	801	1030	1535	2150	2550	3970	5600	6940
WT(BW)	KG	30	30	34	42	46	89	152	280	566	776	990	1483	2085	2475	3880	5495	6820

Class 300

NPS	in	1/2	3/4	1	1-1/2	2	3	4	6	8	10	12	14	16	18	20	22	24
DN	mm	15	20	25	40	50	80	100	150	200	250	300	350	400	450	500	550	600
L(RF)	mm	175	175	191	241	292	356	432	559	660	787	838	889	991	1092	1194	1295	1397
L(BW)	mm	191	191	191	241	292	356	432	559	660	787	838	889	991	1092	1194	1295	1397
H	mm	420	420	420	450	454	580	650	797	1004	1050	1100	1190	1230	1870	2100	2240	2550
W	mm	350*	350*	350*	300	300	300	500	600	600	600	600	700	760	800	900	900	900
WT(RF)	KG	31	32	37	48	52	98	168.5	308	616	845	1220	1540	2160	2560	3980	5610	6940
WT(BW)	KG	30	30	34	42	48	90	156.5	288	585	801	1155	1451	2047	2420	3812	5408	6704

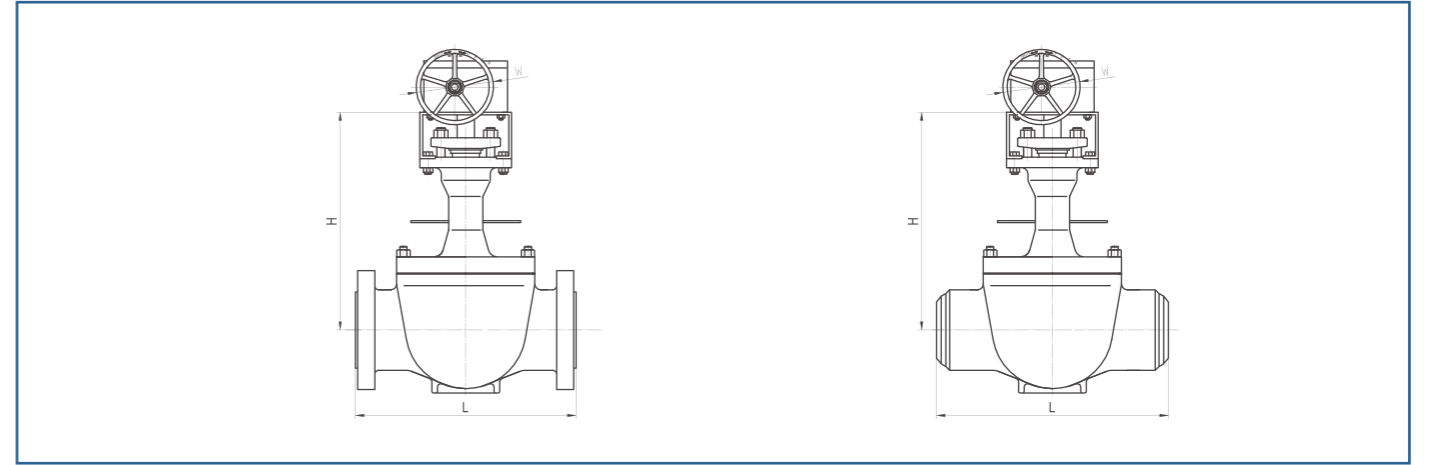

Class 600

NPS	in	1/2	3/4	1	1-1/2	2	3	4	6	8	10	12	14	16	18	20	22	24
DN	mm	15	20	25	40	50	80	100	150	200	250	300	350	400	450	500	550	600
L(RF)	mm	254	254	254	241	292	356	432	559	660	787	838	889	991	1092	1194	1295	1397
L(BW)	mm	191	191	191	241	292	356	432	559	660	787	838	889	991	1092	1194	1295	1397
H	mm	420	420	420	450	454	580	650	801	1034	1100	1150	1220	1265	1900	2120	2270	2580
W	mm	350*	350*	350*	300	300	500	500	600	600	760	760	760	760	800	900	900	900
WT(RF)	KG	31	34	38	45	54	105	177	324	648	889	1525	1860	2170	2570	3985	5620	5950
WT(BW)	KG	30	30	34	40	49	95	160	286	597	801	1420	1735	1990	2350	3715	5300	5578

Class 900

NPS	in	1/2	3/4	1	1-1/2	2	3	4	6	8	10	12	14	16	18	20	22	24
DN	mm	15	20	25	40	50	80	100	150	200	250	300	350	400	450	500	550	600
L(RTJ)	mm	272	272	272	305	368	381	457	610	737	838	965	1029	1130	1219	1321	1435	1549
L(BW)	mm	230	230	244	241	368	381	457	610	737	838	965	1029	1130	1219	1321	1435	1549
H	mm	440	440	440	480	520	580	650	730	810	910	1000	1130	1260	1980	2220	2370	2680
W	mm	200	200	200	300	500	500	600	600	760	760	800	800	800	900	900	900	900
WT(RTJ)	KG	40	45	46	55	68	135	220	450	690	950	1720	2113	2458	3614	4259	5835	7608
WT(BW)	KG	38	42	42	50	63	125	203	412	639	870	1615	1990	2283	3395	3980	5315	7238

Class 1500

NPS	in	1/2	3/4	1	1-1/2	2	3	4	6	8	10	12	14	16	18	20	22	24
DN	mm	15	20	25	40	50	80	100	150	200	250	300	350	400	450	500	550	600
L(RTJ)	mm	272	272	272	305	368	470	546	705	832	991	1130	1257	1384	1537	1664	1800	1950
L(BW)	mm	230	230	244	241	371	473	549	711	841	1000	1146	1276	1407	1559	1686	1829	1972
H	mm	500	500	500	550	600	650	700	850	1000	1290	1350	1500	1690	2180	2430	2610	2810
W	mm	300	300	300	500	600	500	600	600	760	760	900	900	900	1000	1000	1000	1000
WT(RTJ)	KG	43	48	50	55	68	150	250	580	850	1395	2070	2850	3670	5686	6637	8565	11530
WT(BW)	KG	40	45	45	50	48	114	195	150	638	1040	1535	2138	3745	4450	5120	6590	9040



BS6364 SHELL77/200.GB/T24925  
-253°C下使用的

2013年以来,液化天然气行

SIS

56英寸低温蝶 52英寸低温 24英寸1500

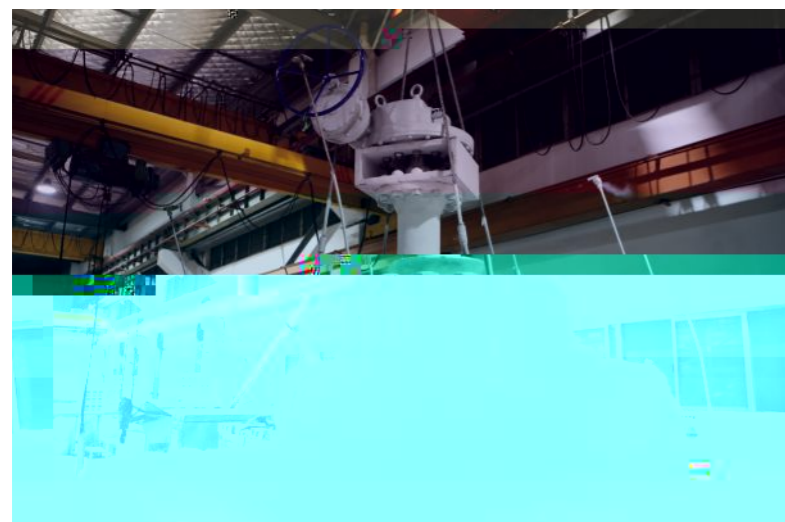

- ① 24 1500
- ② 16 150
- ③ 12 1500
- ④
- ⑤

LNG C

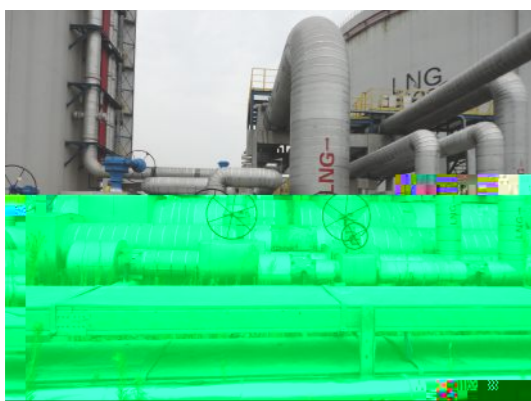
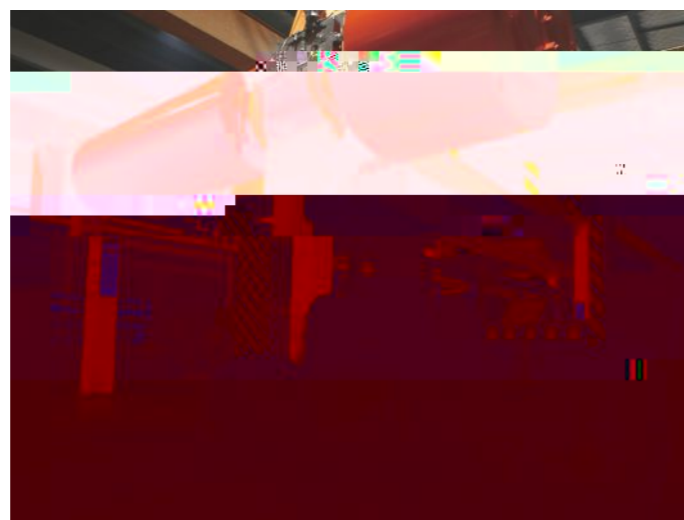

18个月或

12个月以内(以先到

)